

Installation av Lombardini LDW 502 M och Volvo Penta MD1A i Marieholm MS 20 nr. 99, "Helena".

Installation LDW 502 M

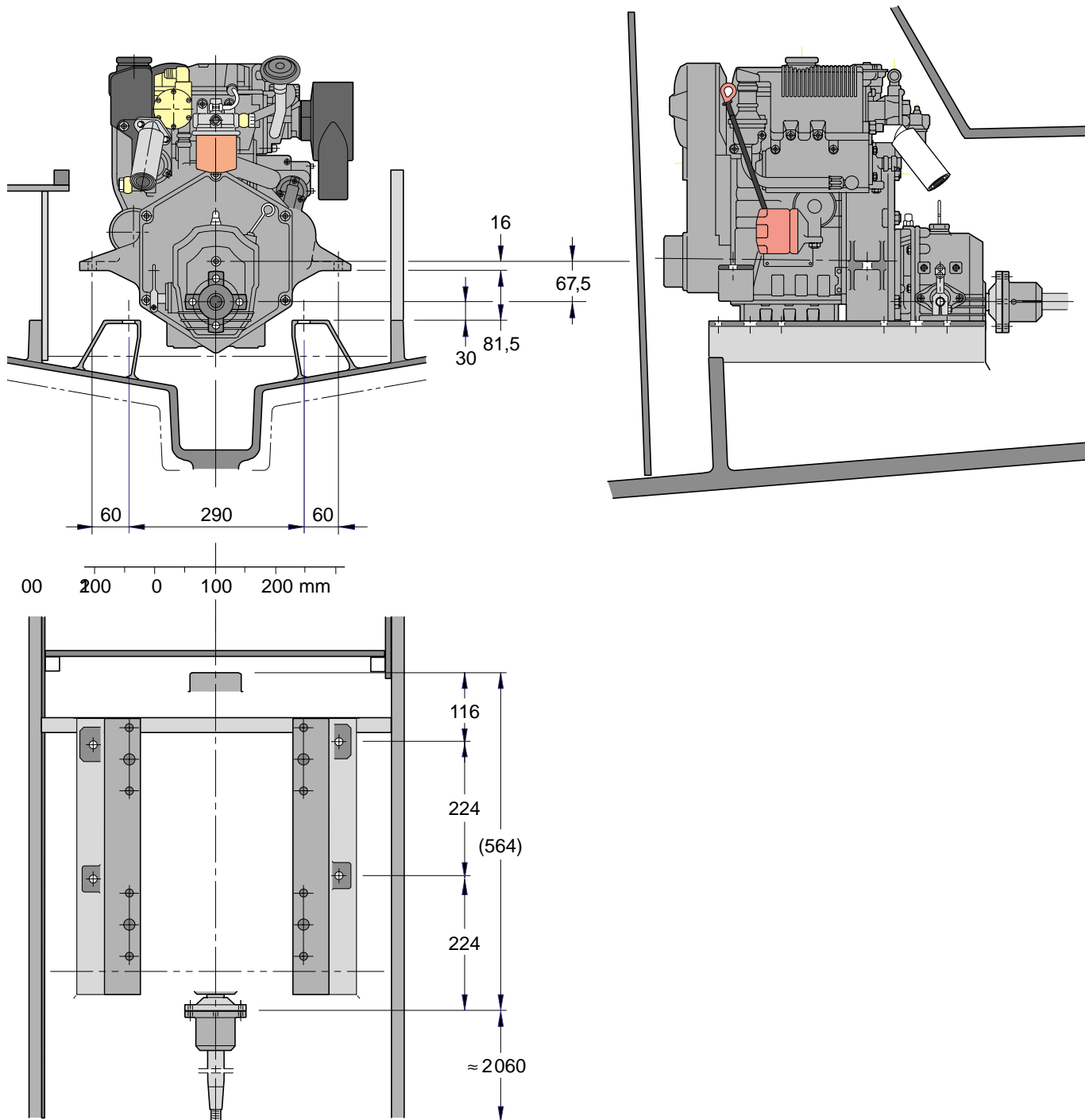

Installation av Lombardini LDW 502 M och Volvo Penta MD1A i Marieholm MS 20 nr. 99, "Helena".

Installationsmått LDW 502 M

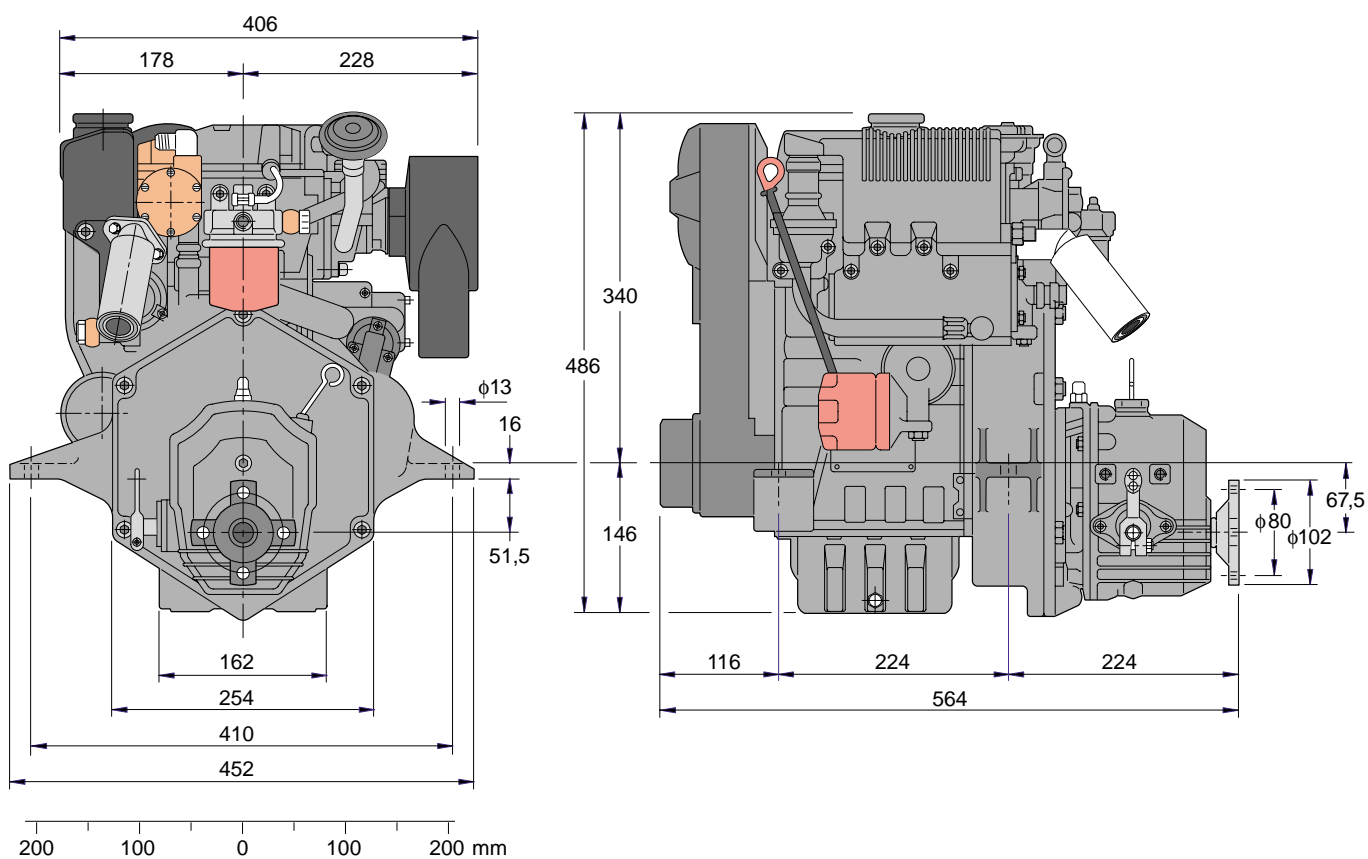

Installation av Lombardini LDW 502 M och Volvo Penta MD1A i Marieholm MS 20 nr. 99, "Helena".

Installation MD1A

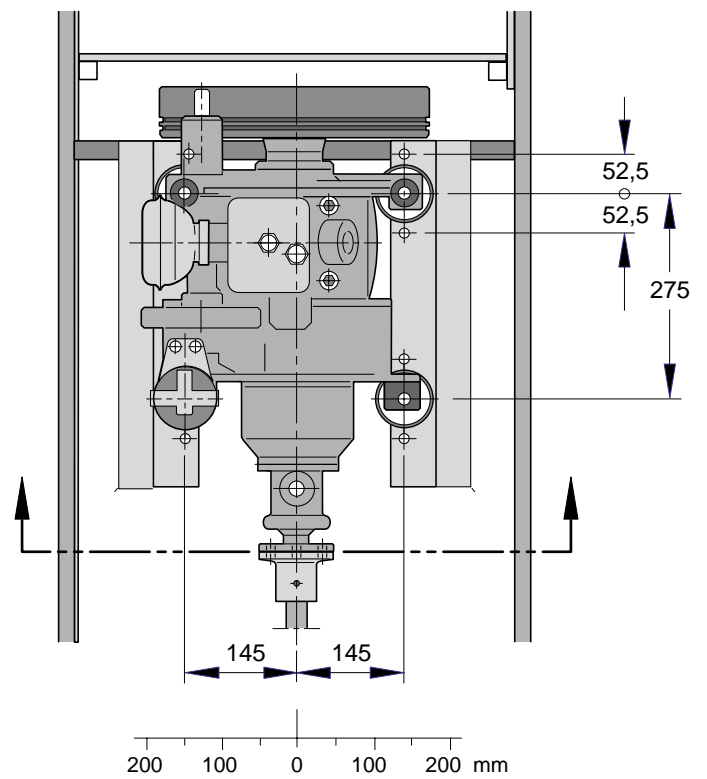
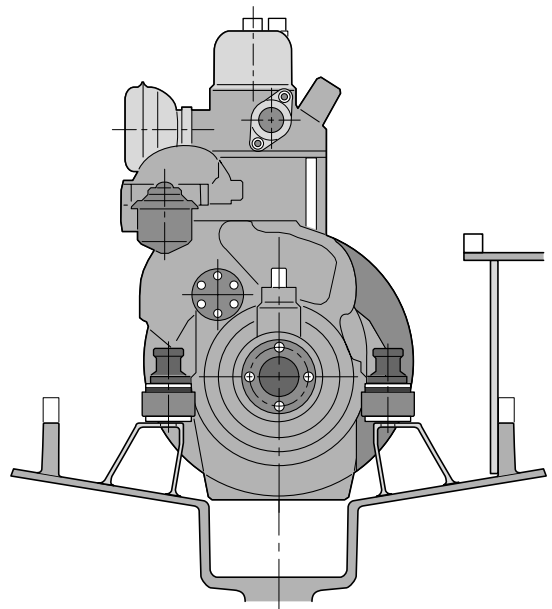
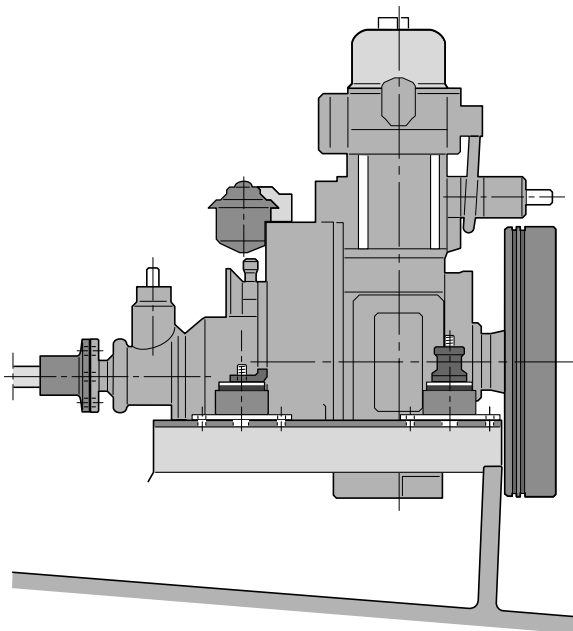

Installation av Lombardini LDW 502 M och Volvo Penta MD1A i Marieholm MS 20 nr. 99, "Helena".

Installationsmått MD1A

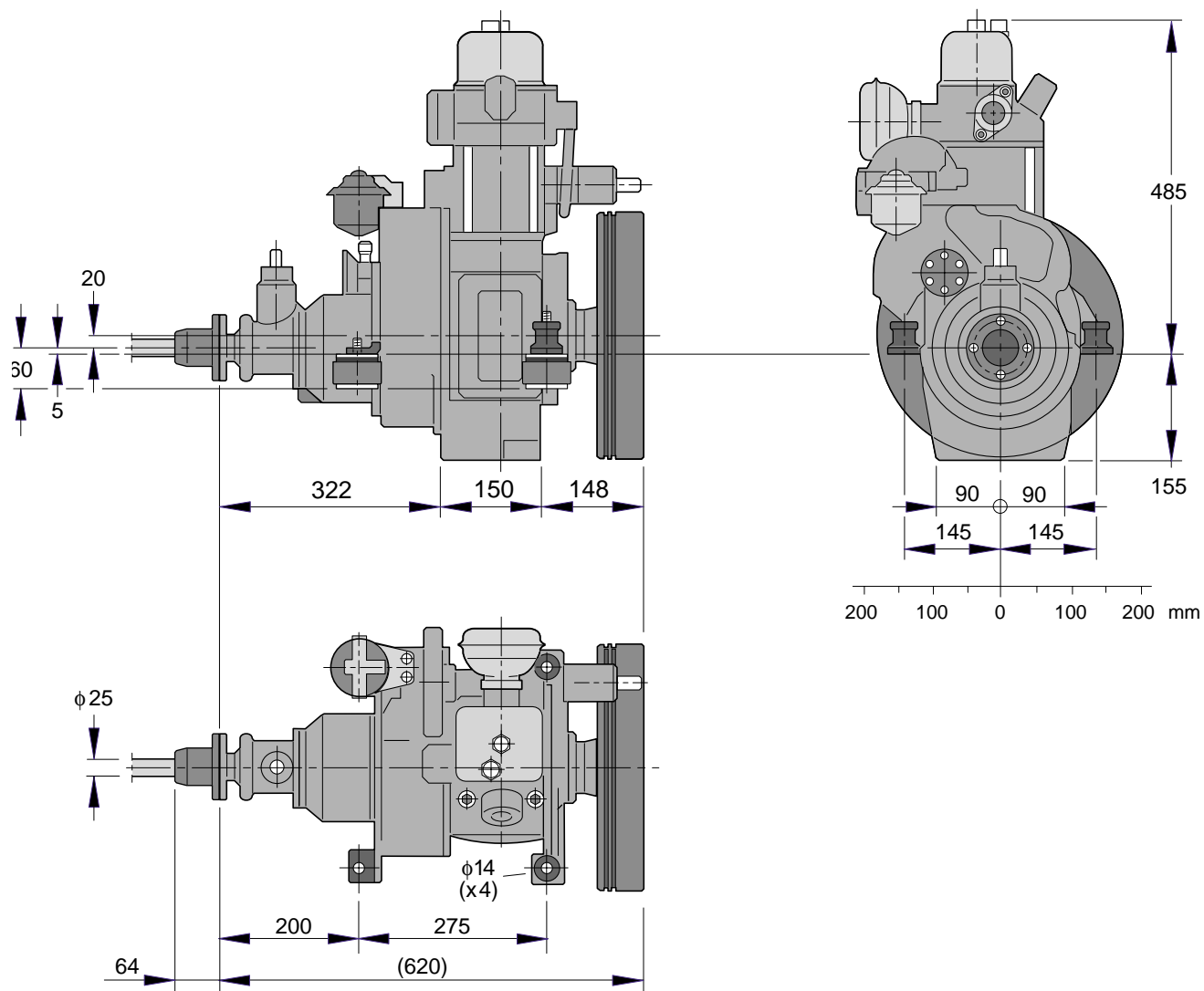

Installation av Lombardini LDW 502 M och Volvo Penta MD1A i Marieholm MS 20 nr. 99, "Helena".

Motorbädd för MD1A inkl. propelleraxel

